

SANHUA P SERIES



Accumulator

P series accumulator is installed between the suction port of the refrigerating system compressors and evaporator to separate gas and fluid, store fluid, return oil and filter.



FEATURES

- INLET AND OUTLET ARE MADE OF COPPER TUBES
- AIR GUIDING PART DIRECT THE REFRIGERANT TOWARD THE WALL WHICH FORM A SLIPSTREAM TO MAKE THE REFRIGERANT EXPAND QUICKLY AND SLOW THE FLOW TO LET THE LIQUID DROP DOWN. THIS EFFECTIVELY SEPARATES THE LIQUID AND GAS.
- THE U TUBE DESIGN GUARANTEE A MAX FLOW OF REFRIGERANT AND STOP LITTLE LUBRICATION OIL. THE INLET OF U TUBE IS BEHIND AIR GUIDING PART WHICH CAN PREVENT THE LIQUID FROM ENTERING COMPRESSOR. AT THE SAME TIME, IT CAN CHANGE THE DIRECTION OF REFRIGERANT TO COMPLETELY SEPARATE THE LIQUID AND GAS.
- THE BALANCING HOLE IN THE UPPER U TUBE CAN EFFECTIVELY ELIMINATE THE SIPHON CAUSED THE RESTART OF SYSTEM SO AS TO AVOID EXCESSIVE LIQUID ENTERING COMPRESSOR.
- THE OIL RETURN HOLE IS MATCHING THE SYSTEM CAPACITY TO OPTIMIZE THE FLOW OF LIQUID REFRIGERANT AND LUBRICATION OIL INTO COMPRESSOR.
- CONNECTION TUBE, U TUBE AND VOLUME OF ACCUMULATOR IS DESIGNED BASED ON THE BASIC DEMAND OF HEAT PUMP SYSTEM INCLUDING SAFETY STORE CAPACITY (VS. TOTAL CAPACITY) ; PROTECTIVE FLOW CONTROL BACK TO COMPRESSOR ALLOWS A PROPER AND RELIABLE LIQUID REFRIGERANT AND LUBRICATION OIL BACK TO COMPRESSOR. THIS COMBINATION IS TO ACHIEVE A MINIMUM PRESSURE DROP AND LARGEST REFRIGERANT CAPACITY.
- POWDER COATED SURFACE CAN SURVIVE 500HOURS OF SALT SPRAY TEST.
- INCORPORATED FUSE OF 430F

GENERAL SPECIFICATIONS

- Applicable refrigerant: CFC, HCFC, HFC etc.
- Applicable medium temperature: -30°C ~+120°C (22°F~+240°F)
- Applicable ambient temperature: -35°C ~+55°C (22°F~+131°F)
- Maximum working pressure: 2.5MPa
- Certification: UL, CSA and PED



CHILLING IDEAS WORLDWIDE

SANHUA INTERNATIONAL EUROPE
sanhuaeurope.com



SANHUA P SERIES Accumulator

TECHNICAL PARAMETERS

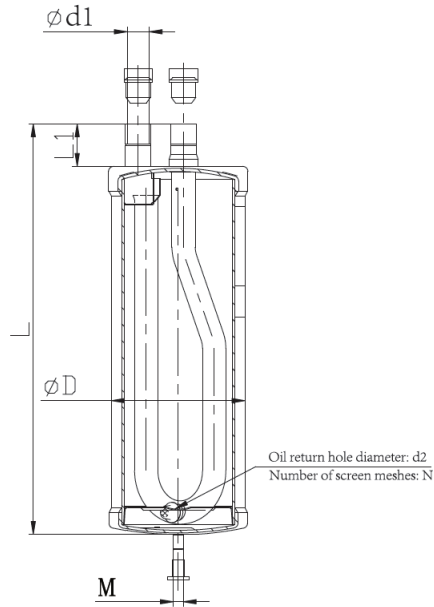

Model	L mm	Screw Size M	D mm	d1 mm	L1 mm	N meshes/ in	d2 mm
ACM-P00076-037	262.9	3/8-16UNC-2A	76	12.7	28.4	30	1.4
ACM-P00076-038	262.9	3/8-16UNC-2A	76	16	28.4	30	1.4
ACM-P00076-027	382.3	3/8-16UNC-2A	76	16	34.3	60	1.4
ACM-P00076-016	382.3	3/8-16UNC-2A	76	19.2	34.3	60	1.4
ACM-P00101-061	190.5	3/8-16UNC-2A	101.6	19.2	34.3	60	1.4
ACM-P00101-057	244.3	3/8-16UNC-2A	101.6	16	27.7	30	0.9
ACM-P00101-074	293.4	M8	101.6	16	27.7	60	0.74
ACM-P00101-063	320	3/8-16UNC-2A	101.6	19.2	34.3	60	1.4
ACM-P00101-064	357.1	3/8-16UNC-2A	101.6	19.2	34.3	30	2.03
ACM-P00101-065	438.2	3/8-16UNC-2A	101.6	22.4	40.4	60	1.0
ACM-P00127-177	244.3	3/8-16UNC-2A	127	22.4	40.4	60	1.4
ACM-P00127-180	287.8	3/8-16UNC-2A	127	19.2	34.3	30	1.4
ACM-P00127-181	327.2	3/8-16UNC-2A	127	22.4	40.4	30	1.4
ACM-P00127-186	389.6	3/8-16UNC-2A	127	22.4	40.4	30	1.4
ACM-P00127-205	438.2	3/8-16UNC-2A	127	22.4	40.4	30	1.4
ACM-P00153-052	381	3/8-16UNC-2A	152.4	28.7	38.1	30	3.2
ACM-P00153-053	388.2	3/8-16UNC-2A	152.4	35.1	40	30	2.03
ACM-P00153-003	400.6	3/8-16UNC-2A	152.4	35.1	45/60	30	1.4
ACM-P00153-054	487.2	3/8-16UNC-2A	152.4	35.1	45	30	1.8
ACM-P00153-043	570	M12	152.4	35.1	40	30	2.03